



FALC

mod. **GRIFUS**

**TRINCIATRICE - BROYEUR - SHREDDER
HÄCKSLER - TRITURADORA**



Trinciatrice con spostamento idraulico per erba, residui di potature medie e residui vegetali. Per trattori da 50 a 90 HP



Broyeur déportable hydraulique pour herbes, sarments moyen et résidus végétaux. Pour tracteurs de 50-90 CV



Shredder with hydraulic offset for grass, medium prunings and vegetal residues. For 50-90 HP tractors



Häcksler mit hydraulischer Verschiebung für Gras, mittel Baumschnitte und Pflanzenreste. Für Traktoren von 50 bis 90 PS



Trituradora con desplazamiento hidráulico para hierba, residuos de podas medios y restos vegetales. Para tractores de 50 a 90 CV





| GRIFUS | | | | | | | | | | |
|--------|-----|------|-------|-------|----------|----------|----|-------|-----|----|
| | Kg. | LBS | A mm. | B mm. | A inches | B inches | N. | HP | PTO | N. |
| 1400 | 480 | 1058 | 1405 | 1593 | 55,31 | 62,72 | 14 | 50-90 | 540 | 3 |
| 1600 | 520 | 1146 | 1585 | 1773 | 62,40 | 69,80 | 16 | 50-90 | 540 | 3 |
| 1800 | 560 | 1235 | 1765 | 1953 | 69,49 | 76,89 | 18 | 50-90 | 540 | 4 |
| 2100 | 610 | 1345 | 2125 | 2313 | 83,66 | 91,06 | 22 | 50-90 | 540 | 4 |
| 2300 | 660 | 1455 | 2305 | 2493 | 90,75 | 98,15 | 24 | 50-90 | 540 | 4 |
| 2500 | 710 | 1565 | 2485 | 2673 | 97,83 | 105,24 | 26 | 50-90 | 540 | 4 |
| 2700 | 760 | 1676 | 2665 | 2853 | 104,92 | 112,32 | 28 | 50-90 | 540 | 4 |

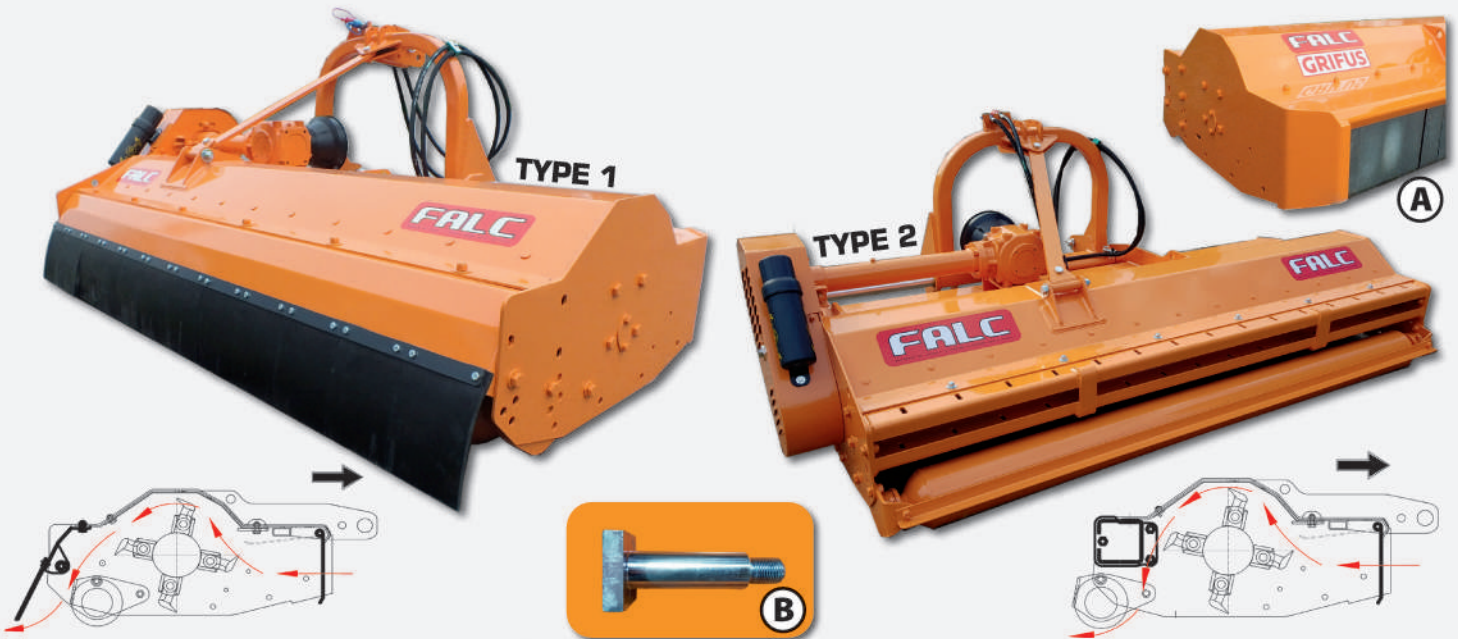

- **TYPE 1:** con rullo posteriore Ø 168x4,5 e scarico del materiale trinciato dietro al rullo
- **TYPE 2:** con rullo posteriore Ø 168x4,5 e barra porta rastrello. **Predisposizione per montaggio ruota interfila e trinci-no a fili interfilare idraulico (TYPE 2)**
- Bocca anteriore alta per favorire l'ingresso del materiale da trinciare (A)
- Spostamento idraulico mm 440
- Controcotello imbullonato
- Perni filettati porta martelli, con dado (B)
- Lamiera d'usura imbullonata (OPZIONE)



- **TYPE 1:** avec rouleau arrière Ø 168x4,5 et décharge du matériel coupé derrière le rouleau
- **TYPE 2:** avec rouleau arrière Ø 168x4,5 et barre porte rateau. **Predisposition pour le montage du tondeuse hydraulique et tête hydraulique intercep à fils (TYPE 2)**
- "Bouche" frontale haute pour faciliter l'entrée du produit à broyer (A)
- Déport hydraulique mm 440
- Contre couteau boulonné
- Axes filetés porte marteaux, avec écrou (B)
- Tôle d'usure boulonnée (OPTION)





- **TYPE 1:** with rear roller Ø 168x4,5 and unloading of chopped material behind the roller
- **TYPE 2:** with rear roller Ø 168x4,5 and rake's bar. **Facility for the assembling of hydraulic inter-row cutting disc and hydraulic inter-row wire chopper (TYPE 2)**
- High front "mouth" to facilitate the entry of the residues to be chopped (A)
- Hydraulic offset mm 440 (inches 17,32)
- Bolted counterblade
- Threaded hammer axles, with nut (B)
- Bolted wear & tear sheet (OPTION)







- **TYPE 1:** mit hinterer Walze Ø 168x4,5 und Entladen des Materials hinter der Walze
- **TYPE 2:** mit hinterer Walze Ø 168x4,5 und Zahnhalterstange. **Veranlagung für hydraulischen Unterstock-Mäher und hydraulisches Unterstock-Schnurmulchgerät (TYPE 2)**
- Hohe vordere Öffnung, den Eintritt des Materials zu erleichtern (A)
- Hydraulische Verschiebung mm 440
- Verschraubtes Gegenmesser
- Hämmer-Gewindebolzen, mit Muttern (B)
- Verschraubtes Verschleißblech (OPTION)



- **TYPE 1:** Con rodillo trasero Ø 168x4,5 y descarga del material picado detrás del rodillo
- **TYPE 2:** Con rodillo trasero Ø 168x4,5 y barra porta rastrello. **Predisposición para ensamblaje de rueda desbrozadora hidráulica y cabezal desbrozador hidráulico para hileras (TYPE 2)**
- Boca anterior alta para facilitar la entrada del material a cortar (A)
- Movimiento hidráulico mm 440
- Contracuchilla atornillada
- Pernos roscado portamartillos, con tuerca (B)
- Chapa de desgaste atornillada (OPCIONAL)



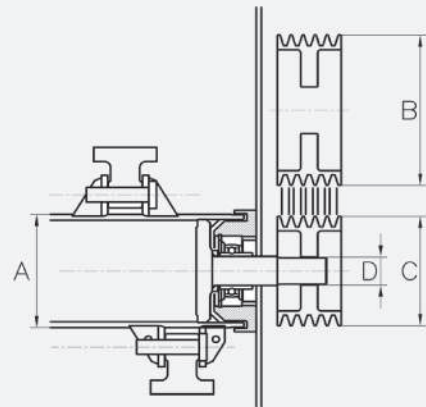

| GRIFUS |  mm |  inches | | | | | | | | |
|--------|---|--|------|-----|------|--|-------|-------|-------|-------|
| 1400 | <table border="1"><tr><td>795</td><td>610</td></tr><tr><td>355</td><td>1050</td></tr></table> | 795 | 610 | 355 | 1050 | <table border="1"><tr><td>31,30</td><td>24,02</td></tr><tr><td>13,98</td><td>41,34</td></tr></table> | 31,30 | 24,02 | 13,98 | 41,34 |
| 795 | 610 | | | | | | | | | |
| 355 | 1050 | | | | | | | | | |
| 31,30 | 24,02 | | | | | | | | | |
| 13,98 | 41,34 | | | | | | | | | |
| 1600 | <table border="1"><tr><td>795</td><td>790</td></tr><tr><td>355</td><td>1230</td></tr></table> | 795 | 790 | 355 | 1230 | <table border="1"><tr><td>31,30</td><td>31,10</td></tr><tr><td>13,98</td><td>48,43</td></tr></table> | 31,30 | 31,10 | 13,98 | 48,43 |
| 795 | 790 | | | | | | | | | |
| 355 | 1230 | | | | | | | | | |
| 31,30 | 31,10 | | | | | | | | | |
| 13,98 | 48,43 | | | | | | | | | |
| 1800 | <table border="1"><tr><td>795</td><td>970</td></tr><tr><td>355</td><td>1410</td></tr></table> | 795 | 970 | 355 | 1410 | <table border="1"><tr><td>31,30</td><td>38,19</td></tr><tr><td>13,98</td><td>55,51</td></tr></table> | 31,30 | 38,19 | 13,98 | 55,51 |
| 795 | 970 | | | | | | | | | |
| 355 | 1410 | | | | | | | | | |
| 31,30 | 38,19 | | | | | | | | | |
| 13,98 | 55,51 | | | | | | | | | |
| 2100 | <table border="1"><tr><td>795</td><td>1330</td></tr><tr><td>355</td><td>1770</td></tr></table> | 795 | 1330 | 355 | 1770 | <table border="1"><tr><td>31,30</td><td>52,36</td></tr><tr><td>13,98</td><td>69,68</td></tr></table> | 31,30 | 52,36 | 13,98 | 69,68 |
| 795 | 1330 | | | | | | | | | |
| 355 | 1770 | | | | | | | | | |
| 31,30 | 52,36 | | | | | | | | | |
| 13,98 | 69,68 | | | | | | | | | |
| 2300 | <table border="1"><tr><td>960</td><td>1345</td></tr><tr><td>520</td><td>1785</td></tr></table> | 960 | 1345 | 520 | 1785 | <table border="1"><tr><td>37,80</td><td>52,95</td></tr><tr><td>20,47</td><td>70,28</td></tr></table> | 37,80 | 52,95 | 20,47 | 70,28 |
| 960 | 1345 | | | | | | | | | |
| 520 | 1785 | | | | | | | | | |
| 37,80 | 52,95 | | | | | | | | | |
| 20,47 | 70,28 | | | | | | | | | |
| 2500 | <table border="1"><tr><td>1130</td><td>1355</td></tr><tr><td>690</td><td>1795</td></tr></table> | 1130 | 1355 | 690 | 1795 | <table border="1"><tr><td>44,49</td><td>53,35</td></tr><tr><td>27,17</td><td>70,67</td></tr></table> | 44,49 | 53,35 | 27,17 | 70,67 |
| 1130 | 1355 | | | | | | | | | |
| 690 | 1795 | | | | | | | | | |
| 44,49 | 53,35 | | | | | | | | | |
| 27,17 | 70,67 | | | | | | | | | |
| 2700 | <table border="1"><tr><td>1240</td><td>1425</td></tr><tr><td>800</td><td>1865</td></tr></table> | 1240 | 1425 | 800 | 1865 | <table border="1"><tr><td>48,82</td><td>56,10</td></tr><tr><td>31,50</td><td>73,43</td></tr></table> | 48,82 | 56,10 | 31,50 | 73,43 |
| 1240 | 1425 | | | | | | | | | |
| 800 | 1865 | | | | | | | | | |
| 48,82 | 56,10 | | | | | | | | | |
| 31,50 | 73,43 | | | | | | | | | |

-  **GIRI AL MINUTO DEL ROTORE**
 -  **TOURS A LA MINUTE DU ROTOR**
 -  **ROTOR'S RPM**
 -  **ROTORUMDREHUNGEN IN DER MINUTE**
 -  **ROTACIONES AL MINUTO DEL ROTOR**
- N. 1910**

A Ø mm 159 inches 6,26
B Ø mm 250 inches 9,84
C Ø mm 212 inches 8,35
D Ø mm 50 inches 1,97







 **OPZIONI**  **OPTIONS**  **OPTIONS**  **OPTIONEN**  **OPCIONES**

- 1. Coppia ruote anteriori in ferro Ø 190 
- 1. Couple de roues antérieures en fer Ø 190 
- 1. Pair of front iron supporting wheels Ø 190 
- 1. Paar Vorderräder aus Eisen Ø 190 
- 1. Par de ruedas anteriores de hierro Ø 190 



-  2. Coppia slitte fisse
-  2. Couple patins fixes
-  2. Pair of fixed skids
-  2. Paar feste Kufen
-  2. Par patines fijos

- 3. Denti di raccolta (solo per TYPE 2) 
- 3. Râteau arrière (seulement pour TYPE 2) 
- 3. Rear rake (only for TYPE 2) 
- 3. Sammelzinkensatz (nur für TYPE 2) 
- 3. Dientes de rastrillo (solo para TYPE 2) 



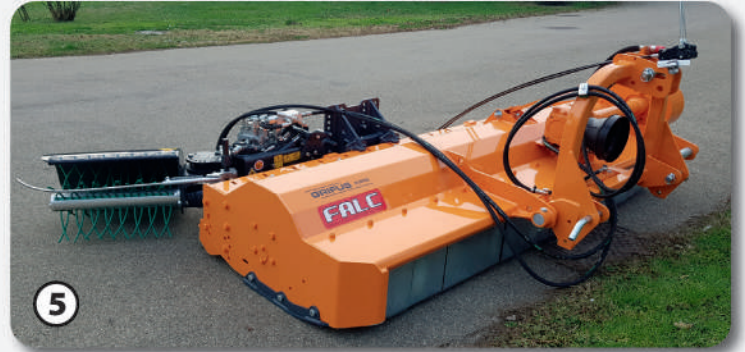

| Ruota interfila idraulica Tondeuse hydraulique intercep Hydraulic inter-row grass cutting disc Hydraulischer Unterstock-Mäher Rueda desbrozadora hidráulica para hileras | | | Kg.* | g/min. t/min. rpm |
|--|---------|-------------|------|-------------------------|
| | 400 mm. | +25° / -15° | 168 | 2000 |
| | 600 mm. | +25° / -15° | 183 | 2000 |
| | 800 mm. | +25° / -15° | 190 | 2000 |



* Peso: ruota interfila+kit montaggio - Poids: tondeuse intercep+kit de montage - Weight: inter-row disc+assembling kit
Gewicht: Unterstock-Mäher+Anbaukit - Peso: rueda desbrozadora+kit montaje

| Trincino a fili interfilare idraulico Hacheuse à fils hydraulique intercep Hydraulic inter-row wire chopper Hydraulisches Unterstock-Schnurmulchgerät Cabezal desbrozador hidráulico de hilos para hileras | Larghezza Largeur Width Breite Ancho | | Kg.* | g/min. t/min. rpm |
|--|--|-------------|------|-------------------------|
| | 500 mm. | +25° / -15° | 150 | 2000 |



* Peso: trincino interfilare+kit montaggio - Poids: hacheuse intercep+kit de montage - Weight: inter-row wire chopper+assembling kit
Gewicht: Schnurmulchgerät + Anbaukit - Peso: Cabezal desbrozador + kit montaje

OPZIONI OPTIONS OPTIONS OPTIONEN OPCIONES



- A RICHIESTA:**
 - Serbatoio olio 60 litri e gruppo pompa (per funzionamento autonomo)
 - Radiatore
 - Joystick
- SUR DEMANDE:**
 - Réservoir d'huile 60 litres et unité de pompage (pour fonctionnement autonome)
 - Radiateur
 - Joystick
- ON REQUEST:**
 - 60 liters oil tank and pump assembly (for self operating)
 - Radiator
 - Joystick
- AUF ANFRAGE:**
 - 60 Liter Öltank und Pumpe (für autonomen Betrieb)
 - Ölkühler
 - Joystick
- A PEDIDO:**
 - Depósito de aceite de 60 litros y grupo de bomba (para funcionamiento autónomo)
 - Radiador
 - Joystick

FALC

Via Proventa, 41
48018 Faenza (Italia)
Tel. +39 0546 29050

www.falc.eu | info@falc.eu

