

FALC

mod. **MASTER SUPER**

**TRINCIATRICE LATERALE E POSTERIORE - BROYEUR D'ACCOTEMENT
LATERAL AND REAR SHREDDER - SEITEN UND HINTERER HÄCKSLER
DESBRUZADORA LATERAL Y POSTERIOR**



Trinciatrice laterale professionale, per erba, cespugli, rovi in frutteti, agrumeti, uliveti e per la manutenzione di bordi stradali. Per trattori da 90 a 150 HP.



Broyeur latéral professionnel, pour herbes, buissons, ronces dans les vergers, les plantations d'agrumes, d'olives et pour l'entretien des routes. Pour tracteurs de 90 à 150 CV.



Professional lateral shredder for grass, bushes and brambles in orchards, citrus groves, olive groves and for roadside maintenance. For 90-150 HP tractors.



Profi Seitenhäcksler, zum Häckseln von Gras, Gebüsch in den Obstgärten, Olivengärten und Wartung am Straßenrand. Für Traktoren von 90 bis 150 PS.



Desbrozadora lateral profesional, para hierba, matas y zarzas en frutales, cítricos, olivares y para el mantenimiento a lo largo de carreteras. Para tractores de 90 a 150 CV.



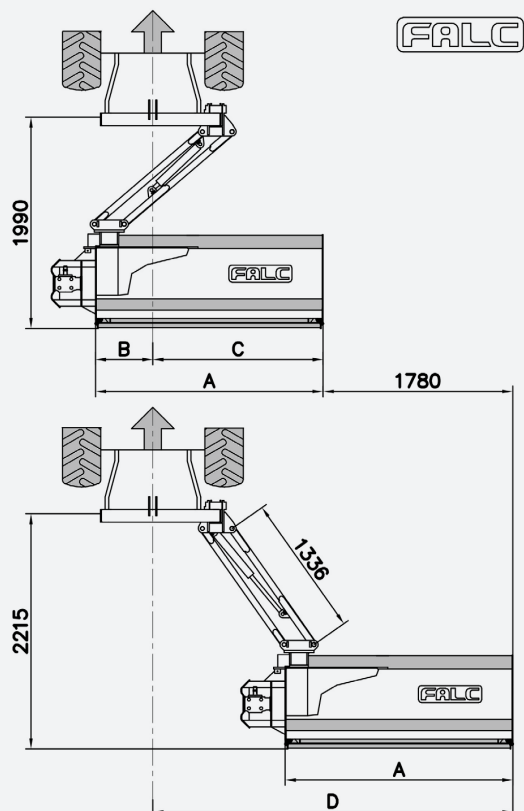

MASTER SUPER	A	B	C	D
1600	1600	540	1060	2840
1800	1780	540	1240	3020
2100	2140	540	1600	3380
2500	2500	540	1960	3740



In presenza di ostacoli un sistema di sicurezza garantisce l'arretramento del trincia, con ritorno automatico.



En cas d'obstacles un dispositif de sécurité permet le recul du groupe de broyage et son retour automatique.



If an obstacle is contacted, a safety system allows the shredder to pivot clear then automatically reset.



Bei Hindernissen gewährt die automatische Sicherung das Ausweichen und das automatische Zurückstellen des Häckslers.



En presencia de obstáculos, un aparato de seguridad garantiza el retroceso de la desbrozadora con retorno automático.



Avvertenza: la trattoria deve essere dotata di 2 prese d'olio a doppio effetto.



Attention: le tracteur doit être équipé avec 2 prises d'huile à double effet.



Attention: the tractor must be equipped with 2 double effect oil plugs.



Achtung: Der chlepper muss mit 2 Doppel-Ölableitungen ausgerüstet sein.



Advertencia: el tractor deberá poseer 2 tomas de aceite de doble efecto.

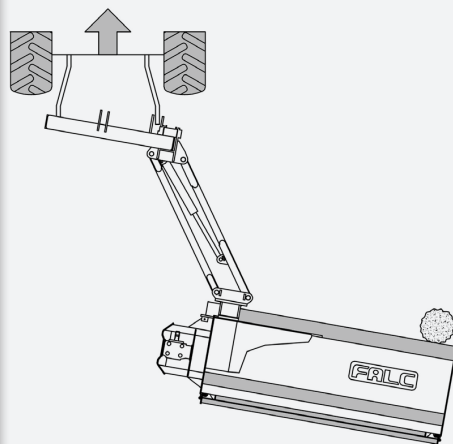
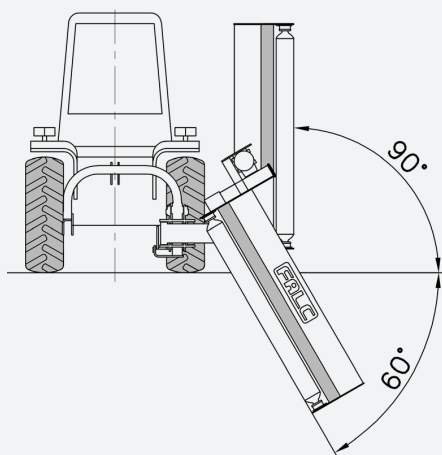

È indispensabile l'uso di albero cardanico con doppio omocinetico.



Il est nécessaire utiliser l'arbre à cardan avec double homocinétique.



It is necessary to use cardan shaft with double CV.



Man darf Doppel-Weitwinkelenkwelle benutzen.



Es indispensable utilizar árbol cardán con homocinética doble.



MASTER SUPER										
	Kg.	LBS	A mm.	B mm.	A inches	B inches	N.	HP	PTO	N.
1600	900	1984	1585	2027	62,40	79,80	16	90-120	540	4
1800	980	2161	1765	2207	69,48	86,89	18	90-120	540	4
2100	1030	2271	2125	2567	83,66	101,06	22	100-120	540	4
2500	1180	2601	2485	2927	97,83	115,24	26	100-150	540	4

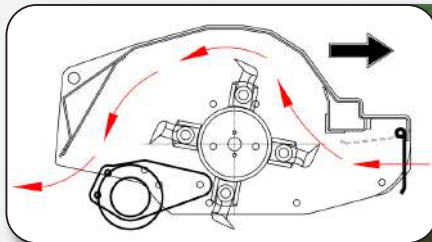

1. Ammortizzatore a molle (opzione)
2. e 3. Martinetti per spostamento laterale e per inclinazione di grandi dimensioni
4. Punto di snodo; tutti gli snodi sono su boccole autolubrificanti
5. Nessun perno è a sbalzo
6. Bracci di spostamento 180 x 60 con punto di snodo 240 x 70
7. Attacco 3° punto 120 x 120
8. Slitte arrotondate

la descrizione continua a pag. 4



1. Amortisseur à ressort (option)
2. et 3. Vérins de déport latéral et déversement de grandes dimensions
4. Point d'articulation: toutes les articulations sont sur de bagues autolubrifiants
5. Tous les pivots sont sur 2 supports
6. Bras de déplacement 180 x 60 avec point d'articulation 240 x 70
7. Attelage 3em point 120 x 120
8. Patins arrondis

la description continue à la page 4



1. Spring shock absorber (option)
2. and 3. Big jacks for lateral shifting and inclination
4. Pivoting point; all joints run on self-lubricating bushes
5. All the pins have 2 supports
6. Shifting arms 180 x 60 with pivoting point 240 x 70
7. 3rd point headstock 120 x 120
8. Round skids

the description continues on page 4



1. Feder – Stoßdämpfer (option)
2. und 3. Große Zylinder für seitliche Verschiebung und Neigung
4. Gelenk; alle Gelenke laufen auf Büchse mit Selbsttätigen Schmierung
5. Alle Bolzen haben 2 Halter
6. Verschiebungsarmen 180 x 60 mit Gelenk 240 x 70
7. 3 Punkt Anschluss 120 x 120
8. Gerundete Kufen

die Beschreibung geht auf Seite 4 weiter



1. Amortiguador de muelles (opción)
2. y 3. Pistones de desplazamiento lateral y inclinación de grandes dimensiones
4. Punto de desarticulación: todas las articulaciones son sobre casquillos autolubricantes
5. Todos los pivotes son con dos soportes
6. Brazos de desplazamiento 180 x 60 con punto de desarticulación 240 x 70
7. Eganche 3° punto 120 x 120
8. Patines de forma arqueada

la descripción continúa en la página 4

mod. MASTER SUPER



90-150 HP

FALC

ROTOR 2250 RPM

- 9. Tubo rotore: Ø mm 194
- 10. Tubo rullo posteriore: Ø mm 168
- 11. Perno filettato porta martello Ø 25
- 9. Tube rotor: Ø mm 194
- 10. Tube rouleau arrière: Ø mm 168
- 11. Axe fileté porte marteau Ø 25
- 9. Rotor tube: Ø mm 194
- 10. Rear roller's tube: Ø mm 168
- 11. Threaded hammer axles Ø 25
- 9. Rohr für Rotor: Ø mm 194
- 10. Rohr für Hinteren Walze: Ø mm 168
- 11. Hammer-Gewindebolzen Ø 25
- 9. Tubo rotor: Ø mm 194
- 10. Tubo rodillo trasero: Ø mm 168
- 11. Perno roscado portamartillo Ø 25

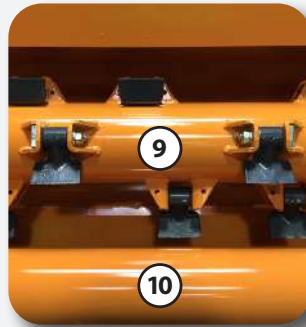

- Velocità periferica:
 - Vitesse périphérique:
 - Tip speed:
 - Umfangsgeschwindigkeit:
 - Velocidad periferica:
- } 53 m/s



OPZIONI OPTIONS OPTIONS OPTIONEN OPCIONES

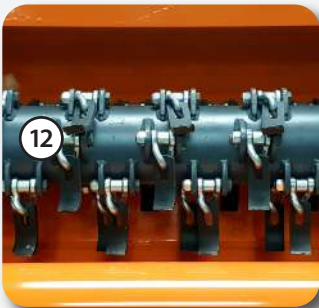

- 12. Rotore con coltelli TLF
- 12. Rotor avec couteaux TLF
- 12. Rotor with TLF blades
- 12. Rotor mit TLF Messern
- 12. Rotor con cuchillas TLF

- 13. Ammortizzatore a molle
- 13. Amortisseur à ressort
- 13. Spring shock absorber
- 13. Feder-Stoßdämpfer
- 13. Amortiguador de muelles



Peso minimo trattrice:	MASTER SUPER 1600	Kg. 3000
Poids minimum tracteur:	MASTER SUPER 1800	Kg. 3500
Minimum weight of tractor:	MASTER SUPER 2100	Kg. 4500
Mindestgewicht des Schleppers:	MASTER SUPER 2500	Kg. 5000
Peso mínimo tractor:		

Larghezza minima trattrice:	MASTER SUPER 1600	mm 1800
Largeur minimum tracteur:	MASTER SUPER 1800	mm 2000
Minimum width of tractor:	MASTER SUPER 2100	mm 2200
Mindestbreite des Schleppers:	MASTER SUPER 2500	mm 2500
Ancho mínimo tractor:		



FALC

Via Proventa, 41
48018 Faenza (Italia)
Tel. +39 0546 29050

www.falc.eu | info@falc.eu

