



FALC

mod. FOX
mod. FOX SPECIAL
mod. FOX VIGNERON

ERPICI ROTANTI - HERSES ROTATIVES - POWER HARROWS
KREISELEGGEN - GRADAS ROTATIVAS



Erpici rotanti per la preparazione del terreno alla semina e per vigneti, frutteti e orticoltura. Per trattori da 40 a 120 HP



Herses rotatives pour la preparation du lit de semence et pour vignobles, vergers et maraichage. Pour tracteurs de 40 à 120 HP



Power harrows for the preparation of the soil ready for sowing and for vineyards, orchards and horticulture. For 40-120 HP tractors







Kreiseleggen für eine ideale Saatbettvorbereitung und für Gemüse, Obst und Weinbau. Für Traktoren von 40 bis 120 PS



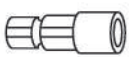
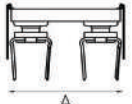

Gradas rotativas para la preparación del terreno de siembra y para viñedos, frutales y horticultura. Para tractores de 40 a 120 HP

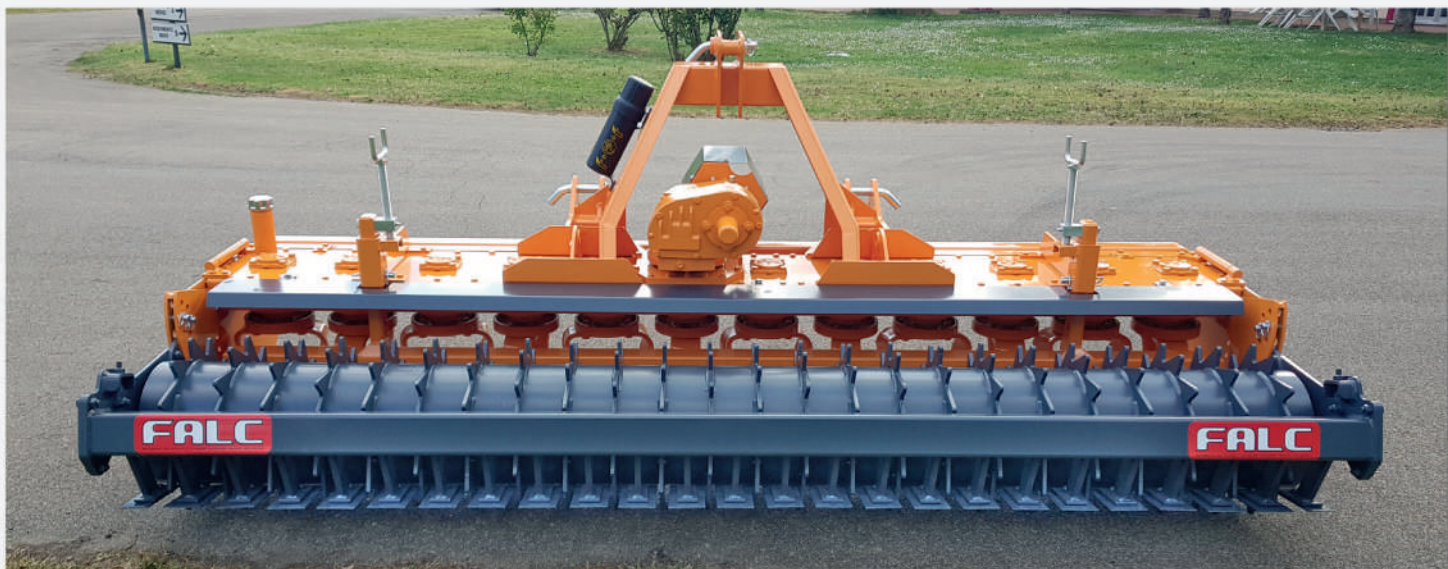

FOX						 Ø460	
	HP.	PTO	A mm.	A inches	Kg.	LBS	N.
2500	70-120	540-1000	2549	100,35	1070	2359	10
3000	70-120	540-1000	3049	120,03	1240	2734	12

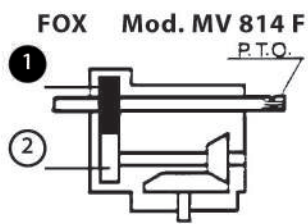

 FOX Mod. MV 814 F P.T.O.	IN DOTAZIONE EN DOTATION ON ISSUE AUSRÜSTUNG EN DOTACIÓN				A RICHIESTA SUR DEMANDE ON REQUEST AUF ANFRAGE A PEDIDO		
	① 30	① 27	① 32	① 25	① 34	① 23	① 21
	② 27	② 30	② 25	② 32	② 23	② 34	② 36
 540	290*	235	334	204	385	176	/
 1000	/	/	/	/	/	327	282

* Velocità inserita - * Vitesse branchée - * Plugged speed - * Eingelegter Gang - * Velocidad predispuesta



1. Tubo anteriore mm 80x80x6 per fissaggio denti rompitraccia
2. Deflettori laterali ripiegabili per ridurre la larghezza massima esterna a mt. 2,99 il mt. 3, a mt. 2,49 il mt. 2,50
3. Barra livellatrice posteriore regolabile
4. PTO posteriore
5. Attacco idraulico Huckepack per seminatrice **(a richiesta)**
6. Ripuntatore rompitraccia frontale **(a richiesta)**



1. Tube avant mm 80x80x6 pour fixation effaceurs de trace
2. Déflecteurs latéraux repliants pour réduire la largeur externe maximum à m 2,99 pour le m 3, à m 2,49 le 2,50
3. Barre niveleuse arrière réglable
4. P.D.F. arrière
5. Attelage hydraulique Huckepack pour semoir **(sur demande)**
6. Effaceur de trace frontal **(sur demande)**



1. Front tube mm 80x80x6 (inches 3,15 x 3,15 x 0,236) for attaching eradicator tines
2. Folding side deflectors to reduce the maximum external width to m 2,99 for m 3, to m 2,49 for m 2,50
3. Rear adjustable levelling bar
4. Rear P.T.O.
5. Hydraulic hitch Huckepack for sowing machine **(on request)**
6. Front trace-breaker **(on request)**







1. Vorderrohr 80x80x6 mm zur Befestigung von Spurlockerern
2. Einklappbarer Seitenschutz zur Verringerung der max. Außenbreite von 3 m auf 2,99m und von 2,50m auf 2,49m
3. Hintere höhenverstellbare Planierschiene
4. Zapfwellendurchtrieb
5. Hydraulische Huckepack Anhängung für Sämaschine **(auf Anfrage)**
6. Vordere Spurlockererzinken **(auf Anfrage)**



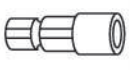

1. Tubo anterior mm 80x80x6 para la fijación de borrahuellas
2. Deflectores laterales replegables para reducir la anchura máxima externa a m 2,99 el m 3, a m 2,49 el m 2,50
3. Barra niveladora posterior regulable
4. T.D.F. posterior
5. Enganche hidráulico Huckepack para sembradora **(a pedido)**
6. Diente borrahuella frontal **(a pedido)**



FOX SPECIAL								GIRI AL MINUTO DEL ROTORE TOURS A LA MINUTE DU ROTOR ROTOR'S RPM ROTORUMDREHUNGEN IN DER MINUTE ROTACIONES AL MINUTO DEL ROTOR 289
	HP.	PTO	A mm.	A inches	Kg.	LBS	N.	
2000	50-100	540	2112	83,14	780	1742	8	
2300	50-100	540	2358	92,83	910	2006	9	
2500	50-100	540	2549	100,35	1030	2271	10	
3000	50-100	540	3049	120,03	1190	2624	12	

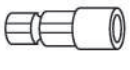
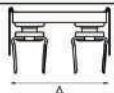
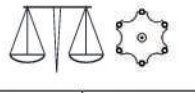

FOX VIGNERON								GIRI AL MINUTO DEL ROTORE TOURS A LA MINUTE DU ROTOR ROTOR'S RPM ROTORUMDREHUNGEN IN DER MINUTE ROTACIONES AL MINUTO DEL ROTOR 289
	HP.	PTO	A mm.	A inches	Kg.	LBS	N.	
1000	40-90	540	1070	42,12	410	904	4	
1300	40-90	540	1316	51,81	450	992	5	
1500	40-90	540	1562	61,49	510	1124	6	
1800	40-90	540	1808	71,18	570	1257	7	



1. Tubo anteriore mm 80x80x6 per **FOX SPECIAL**
Tubo mm 70x70x6 per **FOX VIGNERON**
2. **FOX SPECIAL**: deflettori laterali ripiegabili per ridurre la larghezza massima esterna a mt. 2,99 il mt. 3, a mt. 2,49 il mt. 2,50.
FOX VIGNERON: deflettori laterali fissi (regolabili in altezza)
3. PTO posteriore
4. Barra livellatrice posteriore regolabile **(a richiesta)**
5. Ripuntatore rompitraccia frontale **(a richiesta)**



1. Tube avant mm 80x80x6 pour **FOX SPECIAL**
Tube mm 70x70x6 pour **FOX VIGNERON**
2. **FOX SPECIAL**: déflecteurs latéraux repliants pour réduire la largeur externe maximum à m 2,99 pour le m 3, à m 2,49 le 2,50.
FOX VIGNERON: déflecteurs latéraux fix (réglable en hauteur)
3. P.D.F. arrière
4. Barre niveleuse arrière réglable **(sur demande)**
5. Effaceur de trace frontal **(sur demande)**



1. Front tube mm 80x80x6 (inches 3,15x3,15 x 0,236) for **FOX SPECIAL**
Tube mm 70x70x6 (inches 2,76x 2,76 x 0,236) for **FOX VIGNERON**
2. **FOX SPECIAL**: folding side deflectors to reduce the maximum external width to m 2,99 for m 3, to m 2,49 for m 2,50.
FOX VIGNERON: Fixed side deflectors (height adjustable)
3. Rear P.T.O.
4. Rear adjustable levelling bar **(on request)**
5. Front trace-breaker **(on request)**



1. Vorderrohr 80x80x6 mm für **FOX SPECIAL**
Rohr mm 70x70x6 für **FOX VIGNERON**
2. **FOX SPECIAL**: einklappbarer Seitenschutz zur Verringerung der max. Außenbreite von 3 m auf 2,99 m und von 2,50 m auf 2,49 m. **FOX VIGNERON**: fester Seitenschutz (höheverstellbar)
3. Zapfwelldurchtrieb
4. Hintere höhenverstellbare Planierschiene **(auf Anfrage)**
5. Vordere Spurlockererzinken **(auf Anfrage)**



1. Tubo anterior mm 80x80x6 para **FOX SPECIAL**
Tubo mm 70x70x6 para **FOX VIGNERON**
2. **FOX SPECIAL**: deflectores laterales replegables para reducir la anchura máxima externa a m 2,99 el m 3, a m 2,49 el m 2,50. **FOX VIGNERON**: deflectores laterales fijos (regulables en altura)
3. T.D.F. posterior
4. Barra niveladora posterior regulable **(a pedido)**
5. Diente borrahuella frontal **(a pedido)**

mod. FOX - SPECIAL - VIGNERON



40-120 HP

FALC



- 1. Protezione al cuscinetto superiore
- 2-3. Doppio bloccaggio dell'ingranaggio
- 4. Protezioni ai cuscinetti inferiori
- 5. Protezioni alle viti dei coltelli
- 6. Coltelli (spessore 15 mm)



- 1. Protection au roulement supérieur
- 2-3. Double blocage de l'engrenage
- 4. Protections aux roulements inférieurs
- 5. Protections aux vis des couteaux
- 6. Couteaux (épaisseur 15 mm.)



- 1. Protection of the upper bearing
- 2-3. Double block of the gear
- 4. Protections to the lower bearings
- 5. Protections to the blades screws
- 6. Blades (thickness 15 mm.)

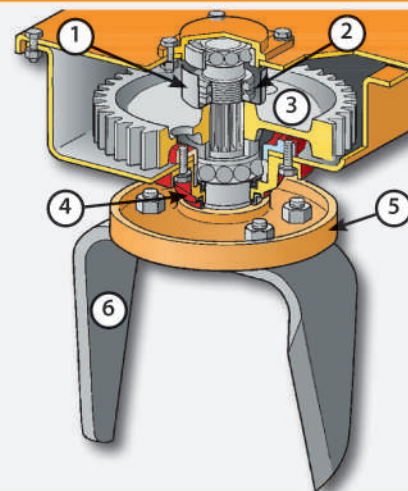

- 1. Schutz des oberen Lagers
- 2-3. Doppelte Getriebeblockierung
- 4. Schutz der unteren Lagern
- 5. Schutz der Messerbefestigungsschrauben
- 6. Messer (Dicke 15 mm)



- 1. Protección al cojinete superior
- 2-3. Doble bloqueo del engranaje
- 4. Protecciones a los cojinetes inferiores
- 5. Protecciones a los tornillos de las cuchillas
- 6. Cuchillas (espesor 15 mm)

OPZIONI OPTIONS OPTIONS OPTIONEN OPCIONES

RULLI - ROULEAUX - ROLLERS - WALZEN - RODILLOS

RULLO A GABBIA - 6 TUBI

ROULEAU A CAGE - 6 TUBES

CAGE ROLLER - 6 TUBES

STABWALZE - 6 ROHRE

RODILLO TUBULAR - 6 TUBOS

RULLO A GABBIA - 8 TUBI

ROULEAU A CAGE - 8 TUBES

CAGE ROLLER - 8 TUBES

STABWALZE - 8 ROHRE

RODILLO TUBULAR - 8 TUBOS

RULLO PACKER Ø 460

ROULEAU PACKER Ø 460

PACKER ROLLER Ø 460

PACKERWALZE Ø 460

RODILLO PACKER Ø 460

RULLO A SPUNTONI Ø 193,7

ROULEAU HERISSON Ø 193,7

SPIKED ROLLER Ø 193,7

SPITZENWALZE Ø 193,7

RODILLO DEDIENTES Ø 193,7



- Protezione sassi
- Protection pierres
- Stone protection
- Steinschutz
- Protección piedras



- Fiancate laterali supplementari
- Flancs lateraux supplementaires
- Supplementary lateral sides
- Extra seitliche Flansche
- Flancos laterales suplementarios



- Coppia rompitraccia
- Couple d'efface trace
- Pair of trace breakers
- Paar Spurlockererzinken
- Par de borrahuellas



FALC

Via Proventa, 41
48018 Faenza (Italia)
Tel. +39 0546 29050

www.falc.eu | info@falc.eu

